



**Cambridge International Examinations**  
Cambridge International General Certificate of Secondary Education

**PHYSICS**

**0625/11**

Paper 1 Multiple Choice (Core)

**May/June 2018**

**45 minutes**

Additional Materials: Multiple Choice Answer Sheet  
Soft clean eraser  
Soft pencil (type B or HB recommended)

\* 8 8 7 1 6 2 1 3 2 4 \*

**READ THESE INSTRUCTIONS FIRST**

Write in soft pencil.

Do not use staples, paper clips, glue or correction fluid.

Write your name, Centre number and candidate number on the Answer Sheet in the spaces provided unless this has been done for you.

**DO NOT WRITE IN ANY BARCODES.**

There are **forty** questions on this paper. Answer **all** questions. For each question there are four possible answers **A, B, C** and **D**.

Choose the **one** you consider correct and record your choice in **soft pencil** on the separate Answer Sheet.

**Read the instructions on the Answer Sheet very carefully.**

Each correct answer will score one mark. A mark will not be deducted for a wrong answer.

Any rough working should be done in this booklet.

Electronic calculators may be used.

Take the weight of 1.0 kg to be 10 N (acceleration of free fall =  $10 \text{ m/s}^2$ ).

The syllabus is approved for use in England, Wales and Northern Ireland as a Cambridge International Level 1/Level 2 Certificate.

This document consists of **15** printed pages and **1** blank page.

- 1 A length of cotton is measured between two points on a ruler.

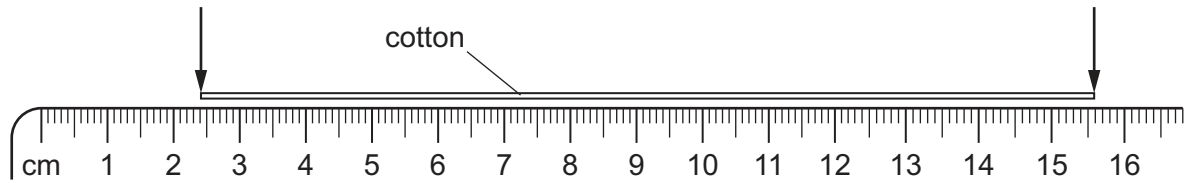

When the length of cotton is wound closely around a pen, it goes round six times.

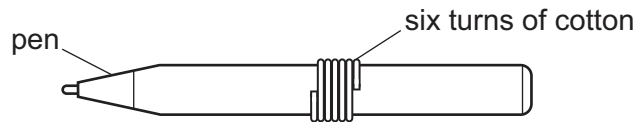

What is the distance once round the pen?

- A** 2.2 cm      **B** 2.6 cm      **C** 13.2 cm      **D** 15.6 cm
- 2 A car is moving along a straight, level road, with a constant acceleration.

Which graph shows the motion of the car?

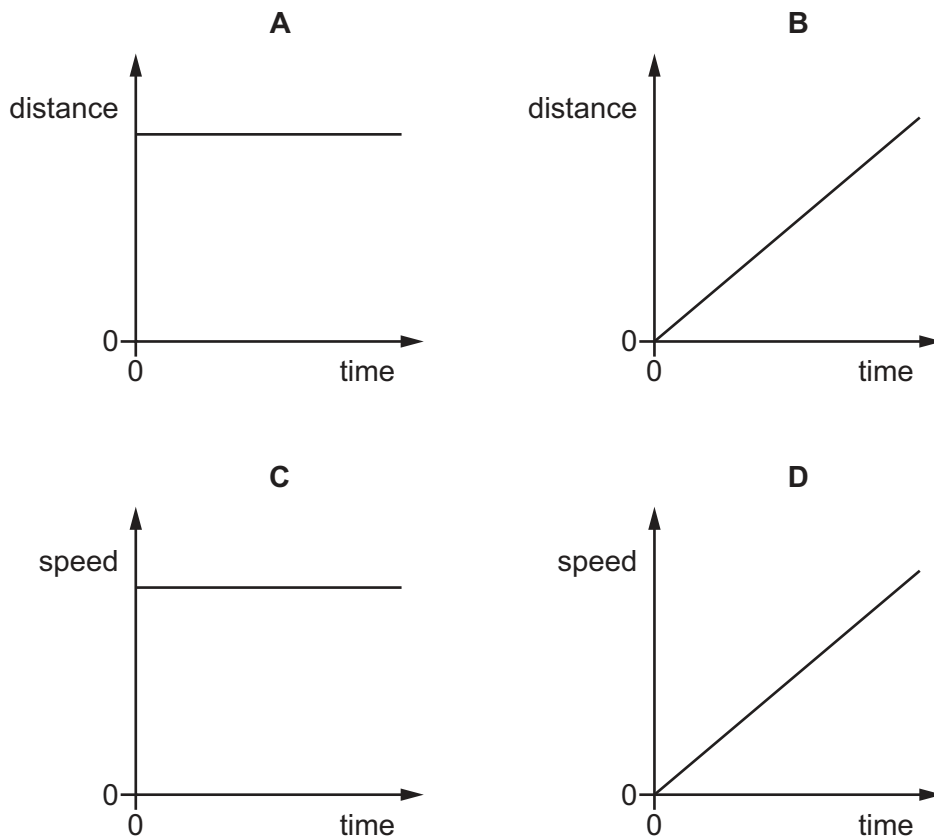

- 3 A car takes 15 minutes to travel along a road that is 20 km long.

What is the average speed of the car?

- A** 0.75 km/h      **B** 5.0 km/h      **C** 80 km/h      **D** 300 km/h

- 4 Diagram 1 shows a beam balance. A beaker with a wire loop balances the standard masses.

The beaker is then removed and hung from a spring. The spring extends by 5.0 cm, as in diagram 2.

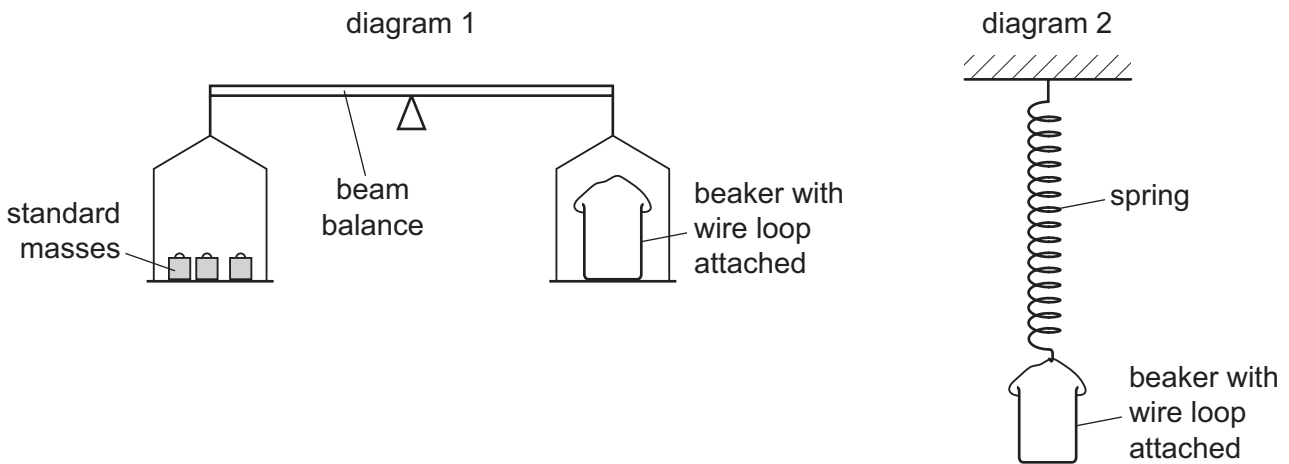

The experiment is repeated with the same apparatus on the Moon, where the acceleration of free fall is less than on Earth.

Which statement describes what happens on the Moon?

- A** The beam balance is balanced and the spring extends by 5.0 cm.  
**B** The beam balance is balanced and the spring extends by less than 5.0 cm.  
**C** The right-hand balance pan is higher and the spring extends by 5.0 cm.  
**D** The right-hand balance pan is higher and the spring extends by less than 5.0 cm.
- 5 An empty beaker is placed on a top-pan balance. Some water is now poured into the beaker.

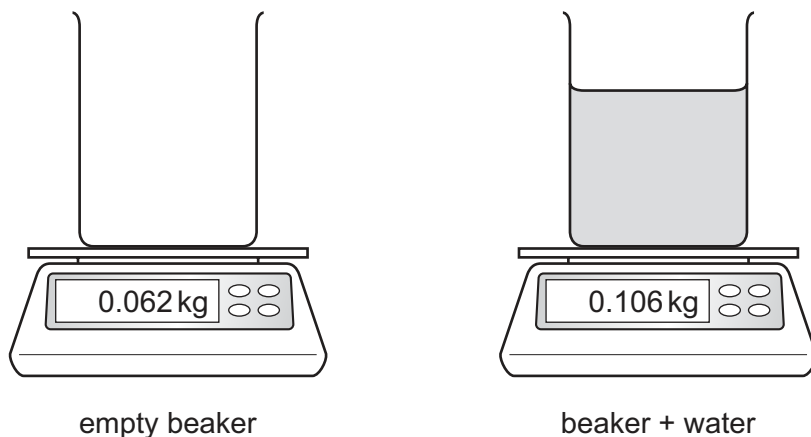

What is the weight of the water?

- A** 0.044 kg      **B** 0.168 kg      **C** 0.0044 N      **D** 0.44 N

- 6 Three liquids P, Q and R have different densities and do not mix. The liquids are placed in a measuring cylinder and allowed to settle. A small block is then dropped into the measuring cylinder and comes to rest, as shown.

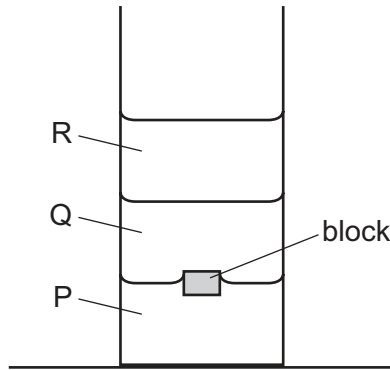

Which statement about the density of the block is correct?

- A It is equal to the density of Q.
  - B It is greater than the density of P.
  - C It is greater than the density of R.
  - D It is less than the density of Q.
- 7 The diagram shows some liquid in a measuring cylinder.

The mass of the liquid is 16 g.

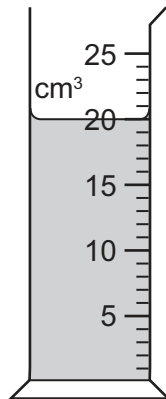

What is the density of the liquid?

- A  $0.80 \text{ g/cm}^3$
- B  $1.25 \text{ g/cm}^3$
- C  $36 \text{ g/cm}^3$
- D  $320 \text{ g/cm}^3$

- 8 A car is moving in a straight line on a level road. Its engine provides a forward force on the car. A second force of equal size acts on the car due to resistive forces.

Which statement describes what happens?

- A The car changes direction.  
 B The car moves at a constant speed.  
 C The car slows down.  
 D The car speeds up.
- 9 A hole is drilled in a square tile. The diagram shows the tile hanging freely on a nail.

Where is the centre of mass of the tile?

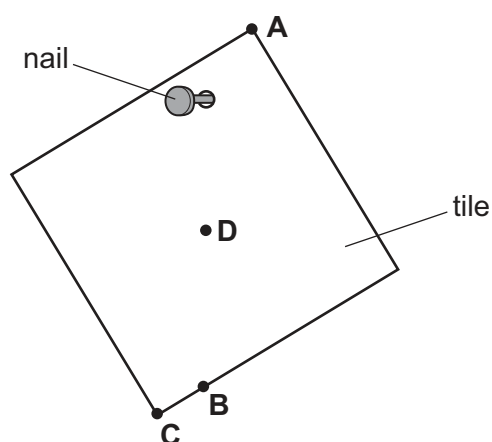

- 10 The diagram shows the energy transferred in a lamp in one second.

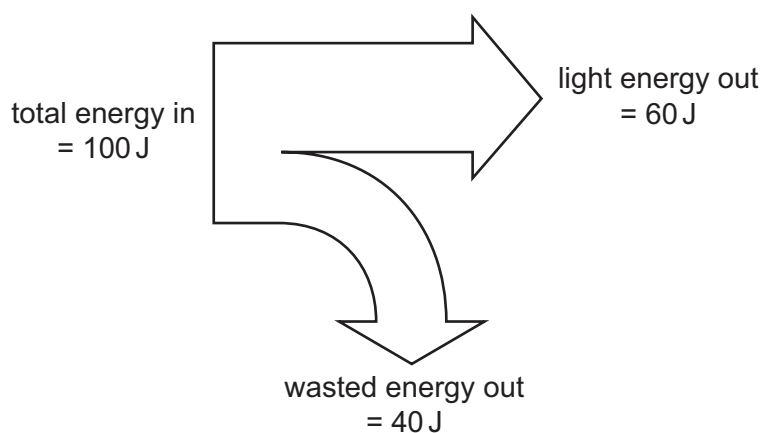

Which type of wasted energy is produced by the lamp?

- A chemical potential energy  
 B electrical energy  
 C gravitational potential energy  
 D thermal energy

11 Which energy resource is **not** renewable?

- A fossil fuel
- B sunlight
- C tides
- D wind

12 A student does work by pulling a box across a horizontal floor.

She now pulls a second box along the same floor.

Which row indicates that the student is now doing twice as much work?

	force used to pull box	distance the box is pulled
<b>A</b>	is doubled	is doubled
<b>B</b>	is doubled	is halved
<b>C</b>	stays the same	is doubled
<b>D</b>	stays the same	is halved

13 Four identical beakers are filled with equal volumes of liquids P or Q, as shown. Liquid P is more dense than liquid Q.

At which point is the pressure the least?

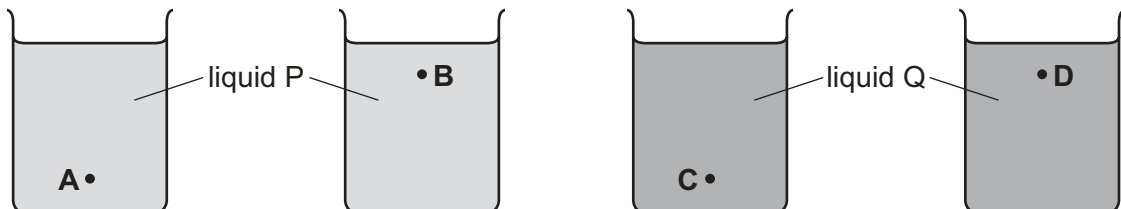

14 A woman has a weight of 600 N. She stands on a horizontal floor. The area of her feet in contact with the floor is  $0.050 \text{ m}^2$ .

What is the pressure she exerts on the floor?

- A  $1.2 \times 10^3 \text{ N/m}^2$
- B  $2.4 \times 10^3 \text{ N/m}^2$
- C  $1.2 \times 10^4 \text{ N/m}^2$
- D  $2.4 \times 10^4 \text{ N/m}^2$

- 15 On a warm day, a carton of fresh milk is covered with a wet cloth.

Why does this help to reduce the temperature of the milk?

- A Some water evaporates from the cloth so the remaining water becomes cooler.
- B The water has a very high thermal capacity.
- C The water insulates the milk from the warm air around it.
- D Water is always colder than the air around it.

- 16 Air is trapped in a cylinder by a piston.

The piston is pushed inwards and the volume of the air is reduced.

The temperature of the trapped air remains constant.

Which row describes how the average speed of the air molecules and the average distance between them changes?

	average speed of molecules	average distance between molecules
<b>A</b>	increases	decreases
<b>B</b>	increases	unchanged
<b>C</b>	unchanged	decreases
<b>D</b>	unchanged	increases

- 17 A wooden wheel can be strengthened by putting a tight circle of iron around it.

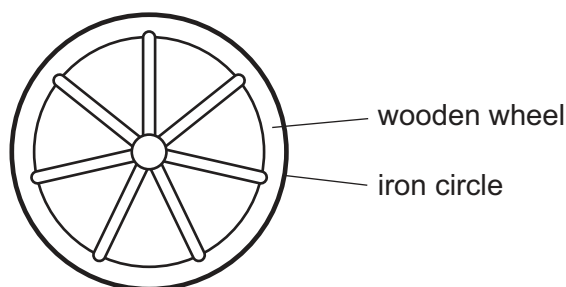

Which action would make it easier to fit the circle over the wood?

- A cooling the iron circle
- B heating the iron circle
- C heating the wooden wheel and cooling the iron circle
- D heating the wooden wheel but not heating or cooling the iron circle

18 A student wishes to calibrate a mercury-in-glass thermometer with a °C scale.

Which values should she use for the lower fixed point and for the upper fixed point?

	lower fixed point	upper fixed point
<b>A</b>	melting point of ice	boiling point of mercury
<b>B</b>	melting point of ice	boiling point of water
<b>C</b>	melting point of mercury	boiling point of mercury
<b>D</b>	melting point of mercury	boiling point of water

19 Which row gives the correct name for each change of state shown?

	change of state		
	gas to liquid	liquid to solid	solid to liquid
<b>A</b>	condensation	melting	solidification
<b>B</b>	condensation	solidification	melting
<b>C</b>	evaporation	melting	solidification
<b>D</b>	evaporation	solidification	melting

20 On a cold day, a metal front-door knob X and a similar plastic knob Y are at the same temperature.

Why does X feel cooler to the touch than Y?

- A** X convects thermal energy better than Y.
- B** X is a better thermal conductor than Y.
- C** X is a better insulator than Y.
- D** X is a better radiator of thermal energy than Y.

21 A liquid is heated and it expands.

How does this lead to the formation of a convection current?

- A** The density of the heated liquid decreases.
- B** The density of the heated liquid increases.
- C** The mass of the heated liquid molecules decreases.
- D** The mass of the heated liquid molecules increases.



22 Which arrow on the graph shows the amplitude of the wave?

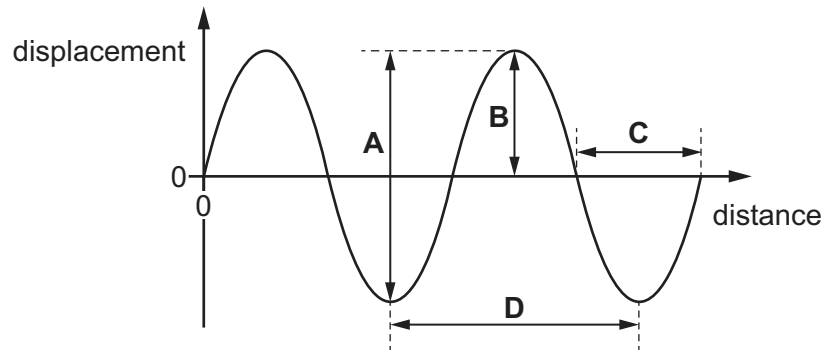

23 In which situation is the wavelength of the wave changed?

- A light from the Sun passing from air into water
- B radio waves travelling from an Earth satellite to the Moon
- C sound reflecting from a wall
- D water waves passing through a narrow gap

24 Scout P signals to scout Q on the other side of a valley by using a mirror to reflect the Sun's light.

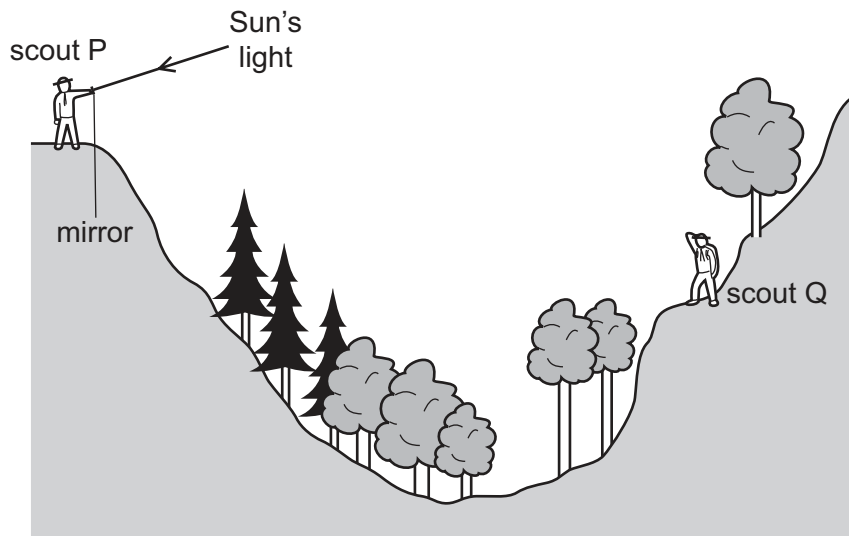

Which mirror position allows the Sun's light to be reflected to scout Q?

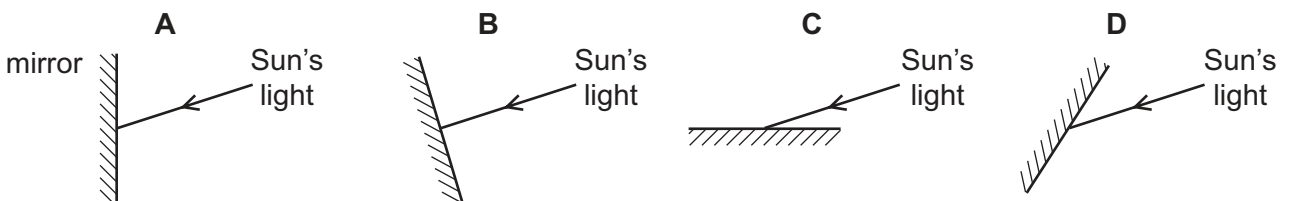

- 25 The diagram shows the electromagnetic spectrum. The numbers indicate the approximate wavelength at the boundaries between the various regions of the spectrum.

For a device to be able to make use of electromagnetic radiation, it needs an aerial of approximately the same size as the radiation it is designed to work with.

P	Q	R	S	T	U	V
	1 m	$10^{-3}$ m	$7 \times 10^{-7}$ m	$4 \times 10^{-7}$ m	$10^{-8}$ m	$10^{-11}$ m

Which statement is correct?

- A A mobile phone uses radiation from region P.  
 B A television satellite dish uses radiation from region Q.  
 C The receptor cells in an eye use radiation from region R.  
 D The remote controller for a television uses radiation from region U.
- 26 A dolphin has a range of audible frequencies of 150 Hz–150 kHz.

Which range of frequencies can be heard both by humans with good hearing and by dolphins?

- A 20 Hz–150 Hz  
 B 20 Hz–150 kHz  
 C 20 kHz–150 kHz  
 D 150 Hz–20 kHz

- 27 A permanent magnet is placed close to a bar of soft iron.



What are the polarities of end P and of end Q?

	end P	end Q
<b>A</b>	N	N
<b>B</b>	N	S
<b>C</b>	S	N
<b>D</b>	S	S

28 Which metal is used for the core of an electromagnet?

- A copper
- B iron
- C magnesium
- D steel

29 The diagram shows a cell connected to three resistors  $R_1$ ,  $R_2$  and  $R_3$ .

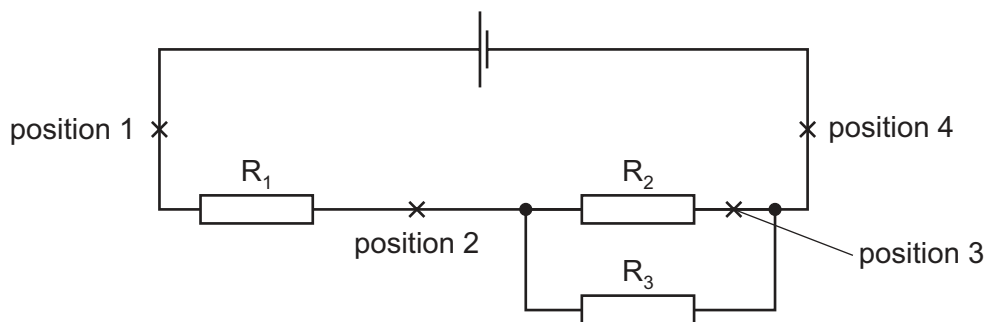

A student connects an ammeter first in position 1, then in position 2, 3 and 4 in turn.

In which positions does the ammeter show the current in  $R_1$ ?

- A 1, 2 and 4
- B 1 and 2 only
- C 3 only
- D 4 only

30 A plastic rod is rubbed with a cloth. The rod becomes positively charged.

What happens to the plastic rod and what is the charge on the cloth?

	plastic rod	charge on cloth
A	gains electrons	negative
B	gains electrons	positive
C	loses electrons	negative
D	loses electrons	positive

31 A student measures the potential difference across a device and the current in the device.

Which calculation gives the resistance of the device?

- A current + potential difference
- B current  $\div$  potential difference
- C potential difference  $\div$  current
- D potential difference  $\times$  current

- 32 The diagram shows three identical resistors, three ammeters and a battery, connected in a circuit.

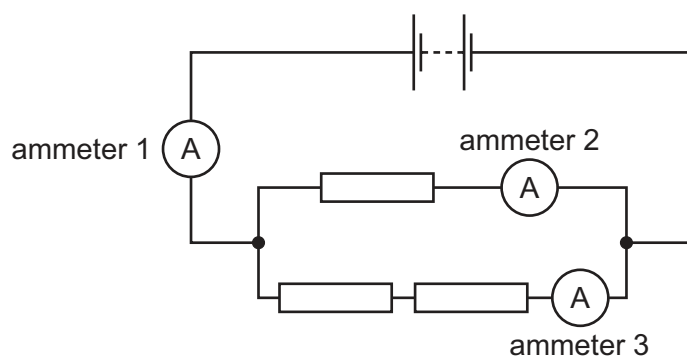

What is the order of the magnitudes of the readings on the ammeters from smallest to largest?

	smallest	intermediate	largest
<b>A</b>	ammeter 1	ammeter 2	ammeter 3
<b>B</b>	ammeter 1	ammeter 3	ammeter 2
<b>C</b>	ammeter 2	ammeter 3	ammeter 1
<b>D</b>	ammeter 3	ammeter 2	ammeter 1

- 33 A student sets up this circuit.

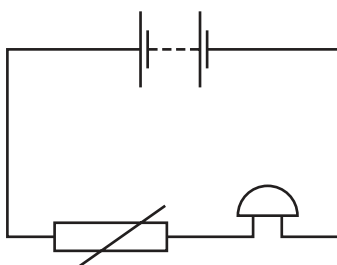

What is the purpose of the circuit?

- A** to allow a lamp to be made dimmer or brighter as required
- B** to amplify the sound of a voice
- C** to light a lamp in the dark
- D** to sound a bell when the temperature rises

- 34 The diagram shows two voltmeters P and Q connected to a potential divider.

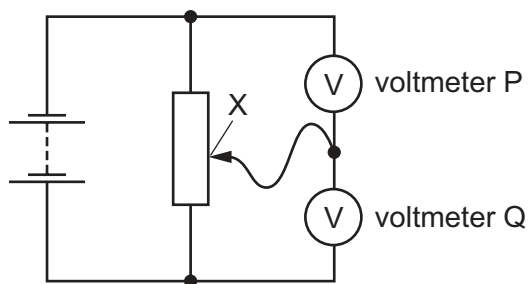

The sliding connection at point X is moved towards the top of the diagram.

What happens to the reading on P and to the reading on Q?

	reading on P	reading on Q
<b>A</b>	decreases	decreases
<b>B</b>	decreases	increases
<b>C</b>	increases	decreases
<b>D</b>	increases	increases

- 35 Which statement about electromagnetic induction is correct?

- A** A strong magnet that is held stationary near a stationary conductor causes a greater effect than a weak magnet.
- B** The effect occurs when a magnet and a conductor are both moved with the same speed and in the same direction.
- C** The effect occurs when a magnet is moved away from a nearby conductor.
- D** The effect only occurs when a magnet is moved towards a conductor.

- 36 An electrical device changes the voltage of an electrical supply from 240 V a.c. to 20 V a.c.

What is this device?

- A** a generator
- B** a relay
- C** a transformer
- D** a voltmeter

- 37 In the atomic model, an atom consists of a central mass, orbited by much smaller particles.

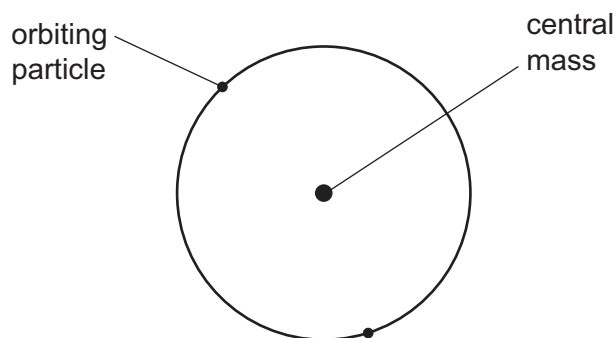

What is the name of the central mass and of the orbiting particles?

	central mass	orbiting particles
<b>A</b>	neutron	$\alpha$ -particles
<b>B</b>	neutron	electrons
<b>C</b>	nucleus	$\alpha$ -particles
<b>D</b>	nucleus	electrons

- 38 A neutral atom of argon-40 ( ${}^{40}_{18}\text{A}$ ) and a neutral atom of potassium-39 ( ${}^{39}_{19}\text{K}$ ) are compared.

Which atom has more electrons, and which atom has more protons?

	more electrons	more protons
<b>A</b>	argon	argon
<b>B</b>	argon	potassium
<b>C</b>	potassium	argon
<b>D</b>	potassium	potassium

- 39 Which statement about  $\alpha$ -particles and  $\beta$ -particles is correct?

- A**  $\alpha$ -particles are less ionising than  $\beta$ -particles.
- B**  $\alpha$ -particles are more penetrating than  $\beta$ -particles.
- C**  $\alpha$ -particles have greater mass than  $\beta$ -particles.
- D**  $\alpha$ -particles have the same charge as  $\beta$ -particles.

**40** An explosion in a nuclear reactor spread the isotope caesium-137 across a large area.

Ninety years after the explosion, the quantity of caesium-137 present will be 12.5% of its original level.

What is the half-life of caesium-137?

- A** 11.25 years    **B** 22.5 years    **C** 30.0 years    **D** 45.0 years

**BLANK PAGE**

---

Permission to reproduce items where third-party owned material protected by copyright is included has been sought and cleared where possible. Every reasonable effort has been made by the publisher (UCLES) to trace copyright holders, but if any items requiring clearance have unwittingly been included, the publisher will be pleased to make amends at the earliest possible opportunity.

To avoid the issue of disclosure of answer-related information to candidates, all copyright acknowledgements are reproduced online in the Cambridge International Examinations Copyright Acknowledgements Booklet. This is produced for each series of examinations and is freely available to download at [www.cie.org.uk](http://www.cie.org.uk) after the live examination series.

Cambridge International Examinations is part of the Cambridge Assessment Group. Cambridge Assessment is the brand name of University of Cambridge Local Examinations Syndicate (UCLES), which is itself a department of the University of Cambridge.